

Wind Power Basics

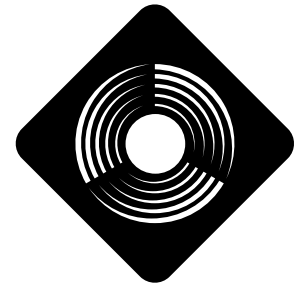

RENEWABLE ENERGY
THE INFINITE POWER
OF TEXAS

SECO FACT SHEET **NO. 13**

HIGHLIGHTS

- ◆ **Wind power is one of the oldest renewable technologies**
- ◆ **As wind speed doubles, power generation capability increases eightfold**
- ◆ **Higher is better: hilltops and tall towers lead to greater energy production**
- ◆ **Unlike fossil fuels, wind power cannot be depleted and produces no pollution**

SUMMARY

Humans have been harnessing the wind ever since farmers in ancient Persia figured out how to use wind power to pump water. Wind power turns the kinetic energy of the wind into mechanical or electrical power than can be used for a variety of tasks. Whether the task is creating electricity or pumping water, the wind offers an inexpensive, clean and reliable form of power. Wind farms are now part of the Texas landscape with 187 megawatts (MW) installed from 1995-2000.

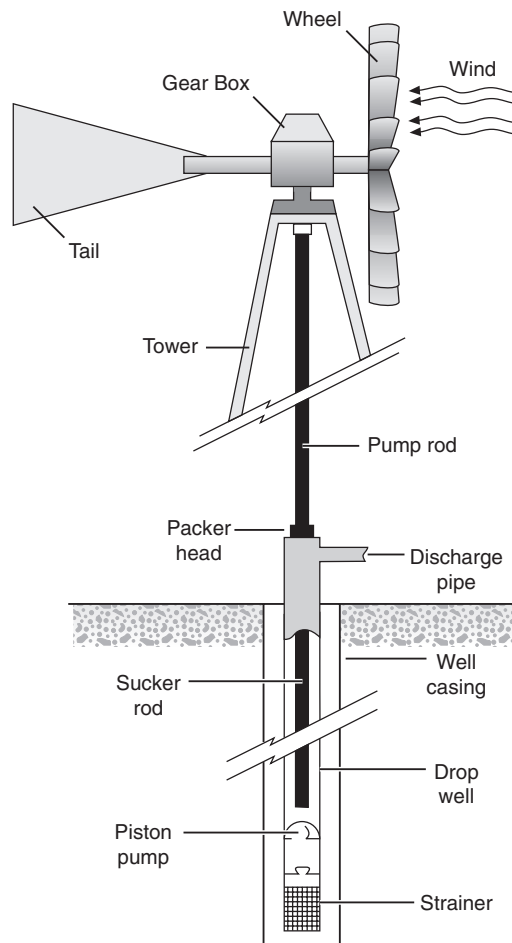

Mechanical pump windmill
These simple wind-driven machines, which utilize a long sucker rod to pump underground water to the surface, were a critical tool in settling the West.

An additional 500 MW are in development for 2001.

WIND ON THE WATER

Whether powering sailboats across the surface of the water or pumping water from one location to another, the wind is a good source of power. Wind provided early explorers with

the engine they needed to cross oceans and discover new lands. On land, the oldest and most widespread use of wind power is for pumping water. In virtually every country on earth, humans are using wind power to either pump water from the ground or move it from one location to another. Here in



RENEWABLE ENERGY
THE INFINITE POWER
OF TEXAS

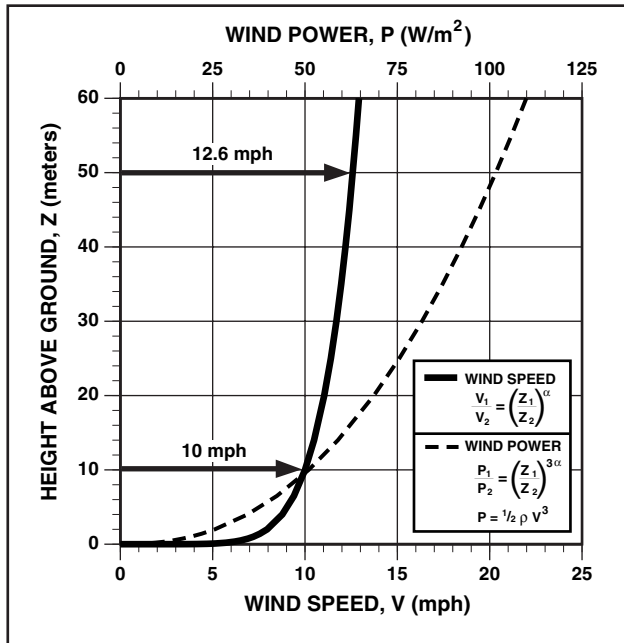

Typical wind shear profile Speed and power available in the wind increases with increasing elevation. The relationship is commonly referred to as the one seventh power law ($a=1/7$)

Texas, where more than 80,000 windmills are in use, rural residents have long relied on windmills to provide water for livestock and human use.

THE HOWS AND WHYS OF WIND POWER

Wind is moving air. The engine that drives this movement is the sun. A good illustration is the sea breeze that blows along the Texas Gulf coast. As the coastal land soaks up sunshine, the air above it heats up and rises. Air over the cooler ocean water then rushes inland. The result is a very dependable wind source suitable for making anything from electricity to windsurfing.

Although modern wind turbines can produce some electricity in light winds, the stronger the breeze the better. Why? The power available in the wind is proportional to the cube of its speed. That means that if the wind speed doubles, say from 10 to 20 miles per hour, the power available to a wind generator increases by a factor of eight, for instance from 1,000 Watts to 8,000 Watts.

One easy way to access higher wind speeds is simply to go up. Winds high above the ground are stronger than winds near the ground. On average a five-fold increase in elevation, say raising the height of the wind machine from 10 feet to 50 feet, will result in twice as much

available wind power. That's why wind turbines are perched on tall towers and are often located on mountains or hilltops.

Given the need for strong winds, finding the best sites for commercial wind farms is critical. The location of power plants fueled by wind must be near existing power lines and in the windiest sites available. To compete head-to-head with fossil fuel generating technologies, wind turbines are best located in areas where wind speeds are 16-20 mph at 50 m height. Wind farms are located in the most windy areas and close to utility power lines. In Texas, the best

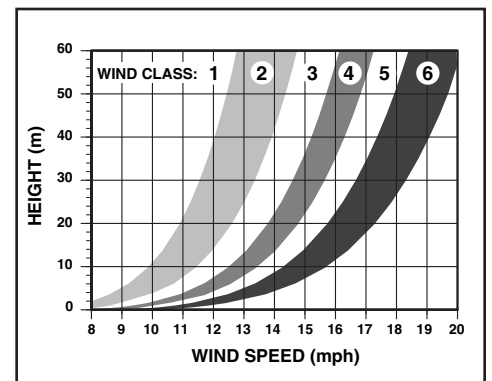

Wind power depends on elevation and wind speed Wind Class is a relative scale used to characterize wind potential of any location. Wind Class of 3 and above are generally regarded as being suitable for commercial wind farm development.

locales are found in West Texas and the Texas Panhandle.

Air temperature is also an important factor in wind power generation. Cold air is more dense than hot air. Thus, wind turbines are able to generate about 5% more power at any given wind speed in the winter than they are during the hot days of summer.

MAKING WATTS FROM WIND

The blades on a wind turbine are similar to the propeller blades on an airplane. The rotor blades generate lift from the passing wind, causing them to rotate the hub of the turbine. The rotating action of the hub then turns a generator, which creates electricity. A gearbox is generally necessary to optimize the power output from the machine. That power is then either fed into the electric grid or stored in batteries for use on-site.

While wind speed is important, so is the size of the rotor. On a turbine, the power available to the blades is proportional to the square of the diameter of the rotor. In other words, simply by making the turbine blades twice as long and beef-

ing up the generator, you increase the power producing capability of the turbine by a factor of four.

Modern wind turbines come in two varieties: horizontal axis and vertical axis. Horizontal axis turbines have blades that spin on an axis that is parallel to the ground. These systems often look like the propeller on an airplane. Vertical axis systems have blades that spin on a vertical axis giving them an appearance somewhat like giant egg beaters.

Although large utilities are getting the most attention for their move into wind power, rural residents in all 50 states and dozens of foreign countries have quietly been installing small-scale wind generation systems. These systems can be obtained for as little as \$1,000 and are perfect compliments to photovoltaic systems. Several vendors sell ready-made towers and turbines that are easily installed.

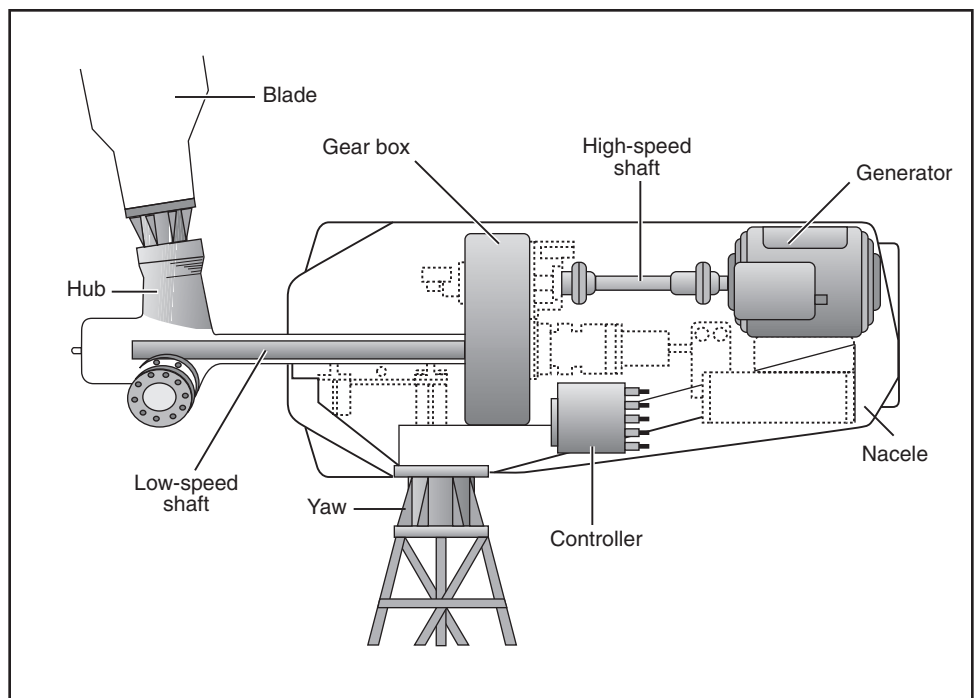

Electricity generating wind turbine *The major components of this device are the blades, shaft, gearbox and generator. On large machines, additional controllers and drive motors ensure that the machine is positioned for optimal capture of the wind.*

ORGANIZATIONS

Alternative Energy Institute

Box 60215, WTAMU
Canyon, TX 79016
(806) 651 2295
www.wtamu.edu/research/aei or
www.windenergy.org

American Wind Energy Association

122 C Street, N.W.
Washington, D.C. 20001
(202) 383-2505
www.awea.org

CADDET

Center for Renewable Energy

1617 Cole Blvd
Golden, CO 80401-3393
(303) 275-4373
www.caddet-re.org

National Renewable Energy Laboratory

1617 Cole Blvd.
Golden, CO 80401-3393
(303) 275-3000
www.nrel.gov

Texas Solar Energy Society

P. O. Box 1447
Austin, TX 78767-1447
(512) 326-3391
e-mail: info@txses.org
www.txses.org

Texas Renewable Energy Industries Association

P. O. Box 16469
Austin, TX 78761
(512) 345-5446
www.treia.org

RESOURCES

FREE TEXAS RENEWABLE ENERGY INFORMATION

For more information on how you can put Texas' abundant renewable energy resources to use in your home or business, visit our website at www.InfinitePower.org or call us at 1-800-531-5441 ext 31796. Ask about our free lesson plans and videos available to teachers and home schoolers.

ON THE WORLD WIDE WEB:

Frequently asked questions/technical advice at **American Wind Energy Association**
www.awea.org/faq/index.html

Lots of information, wind energy and wind turbines: **Danish Wind Turbine Manufacturers Association**
www.windenergy.dk

For home owner size wind turbines
homepower.com/download2.htm#Wind

BOOKS:

Wind Energy and Wind Turbines. Vaughn Nelson, AEI, Revised September 2000.
(Available from the Alternative Energy Institute)

Introduction to Wind Energy. Vaughn Nelson, Earl Gilmore and Kenneth Starcher, AEI Report 94-2. (Available from the Alternative Energy Institute)

Wind Characteristics, An Analysis for the Generation of Wind Power. Janardan Rohatgi and Vaughn Nelson, 1994. (Available from the Alternative Energy Institute)

Wind Energy Basics, A Guide to Small and Micro Wind Systems.
Paul Gipe, Chelsea Green Publishing, 1999.

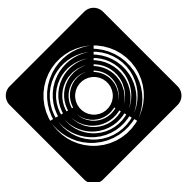

RENEWABLE ENERGY
THE INFINITE POWER
OF TEXAS

STATE ENERGY CONSERVATION OFFICE

111 EAST 17TH STREET, ROOM 1114
AUSTIN, TEXAS 78774

PH. 800.531.5441 ext 31796

www.InfinitePower.org